

GAMCO CORPORATION COMPUTER SIMULATION REPORT

SCOPE OF WORK

TD350 DOOR W/ FG451IS FRAME SINGLE DOOR - 1-3/8" IG (WITH FOAM) - AAMA 507

REPORT NUMBER

Q0188.01-116-45 R0

TEST DATE

10/18/23

ISSUE DATE

10/18/23

PAGES

20

DOCUMENT CONTROL NUMBER

RT-R-AMER-Test-3753 (02/20/18)

©2017 INTERTEK

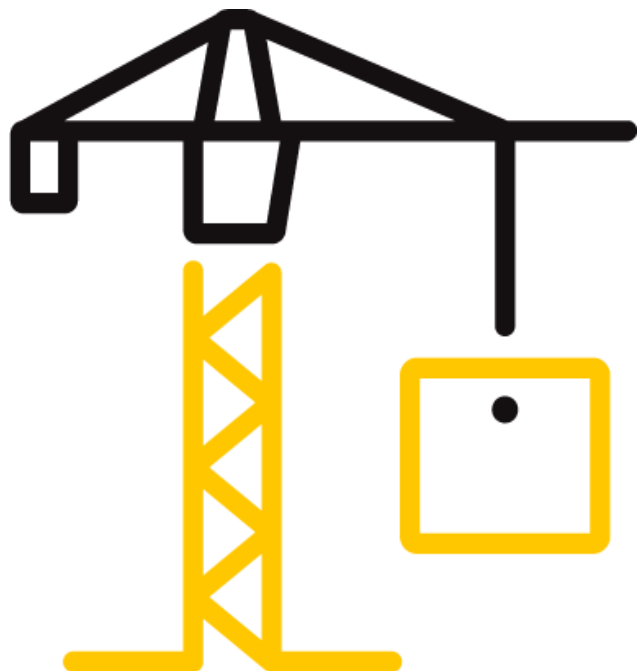

TEST REPORT FOR GAMCO CORPORATION

Report No.: Q0188.01-116-45 R0

Date: 10/18/23

REPORT ISSUED TO

GAMCO CORPORATION

131-10 Maple Avenue

Flushing, New York 11355

SECTION 1

SUMMARY

SERIES/MODEL: TD350 Door w/ FG451IS Frame Single Door - 1-3/8" IG (With Foam)

Architectural Testing, Inc. (an Intertek company), dba Intertek Building & Construction (Intertek B&C) was contracted to perform AAMA 507 computer simulations utilizing thermal thermal modeling computer software developed by Lawrence Berkeley National Laboratory Laboratory (LBNL). Results obtained are simulated values and were secured using the designated test methods.

Intertek B&C is an NFRC accredited simulation laboratory and all simulations were conducted in full compliance with NFRC approved procedures and specifications.

This report does not constitute certification of this product nor an opinion or endorsement by this laboratory. The record retention end date of this report is 10/18/28.

For INTERTEK B&C:

COMPLETED BY: Allison M. Ford
TITLE: Technician Team Leader
SIGNATURE:
DATE: 10/18/23

AMF:amf

REVIEWED BY: Eric S. Leitner
TITLE: Manager - Thermal Testing & Simulations
SIGNATURE:
DATE: 10/18/23

This report is for the exclusive use of Intertek's Client and is provided pursuant to the agreement between Intertek and its Client. Intertek's responsibility and liability are limited to the terms and conditions of the agreement. Intertek assumes no liability to any party, other than to the Client in accordance with the agreement, for any loss, expense or damage occasioned by the use of this report. Only the Client is authorized to permit copying or distribution of this report and then only in its entirety. Any use of the Intertek name or one of its marks for the sale or advertisement of the tested material, product or service must first be approved in writing by Intertek. The observations and test results in this report are relevant only to the sample(s) tested. This report by itself does not imply that the material, product, or service is or has ever been under an Intertek certification program.

TEST REPORT FOR GAMCO CORPORATION

Report No.: Q0188.01-116-45 R0

Date: 10/18/23

SECTION 2

TEST METHODS

The products were evaluated in accordance with the following:

AAMA 507-15, Standard Practice for Determining the Thermal Performance Characteristics of Fenestration Systems Installed in Commercial Buildings

ANSI/NFRC 100-2023, Procedure for Determining Fenestration Product U-Factors

ANSI/NFRC 200-2023, Procedure for Determining Fenestration Product Solar Heat Gain Coefficient and Visible Transmittance at Normal Incidence

SECTION 3

TEST PROCEDURE

The total product, including specific frame, spacer, and glass details, was modeled using NFRC approved software.

FRAME AND EDGE MODELING	THERM 7.8.71
CENTER-OF-GLASS MODELING	WINDOW 7.8.71
TOTAL PRODUCT CALCULATIONS	WINDOW 7.8.71
SPECTRAL DATA LIBRARY	IGDB 93.0

Modeling Assumptions / Technical Interpretations

Any modeling assumptions and technical interpretations required to model this product are listed below.

- 1) To prevent air infiltration, tape was applied to all interior sash crack locations.
- 2) This product is available in either a painted or anodized finish. These two finish types may be grouped in accordance with ANSI/NFRC 100-2023, Section 4.2.1.L. The painted finish was simulated since it is the worst case (highest emissivity).
- 3) Non-continuous hardware was not modeled.

TEST REPORT FOR GAMCO CORPORATION

Report No.: Q0188.01-116-45 R0

Date: 10/18/23

SECTION 4

SIMULATION SPECIMEN DESCRIPTION

SERIES/MODEL	TD350 Door w/ FG451IS Frame Single Door - 1-3/8" IG (With Foam)
PRODUCT TYPE	Swinging Door - Single
FRAME MATERIAL	AT - Aluminum w/ Thermal Breaks - All Members
SASH MATERIAL	AT - Aluminum w/ Thermal Breaks - All Members

GLAZING OPTIONS					
	<i>OUTER PANE</i>	<i>MIDDLE PANE</i>	<i>INNER PANE</i>	<i>GAP SIZES</i>	<i>IG OVERALL</i>
GL1	1/4"	N/A	1/4"	0.500"	1"
GL2	1/4"	Heat Mirror	1/4"	0.250"	1"

GL1: Dual glazed IG unit (COG=0.48 - COG=0.20)

GL2: Dual glazed IG unit w/ heat mirror (COG=0.18 - COG=0.10)

SPACER OPTIONS			
<i>TYPE</i>	<i>PRIMARY SEAL</i>	<i>SECONDARY SEAL</i>	<i>CODE</i>
Generic Aluminum Dual Seal Spacer	Butyl Rubber	Butyl Rubber	A1-D

SECTION 5

MEASURED SIMULATION DATA

U-FACTOR CALCULATIONS	
Exterior Air Temperature	-0.4°F
Exterior Wind Velocity	12.3 mph (Perpendicular Flow)
Interior Air Temperature	69.8°F

TEST REPORT FOR GAMCO CORPORATION

Report No.: Q0188.01-116-45 R0

Date: 10/18/23

SECTION 6

SIMULATION RESULTS

U-FACTOR CALCULATIONS: System U-Factor vs. Percentage of Vision Area

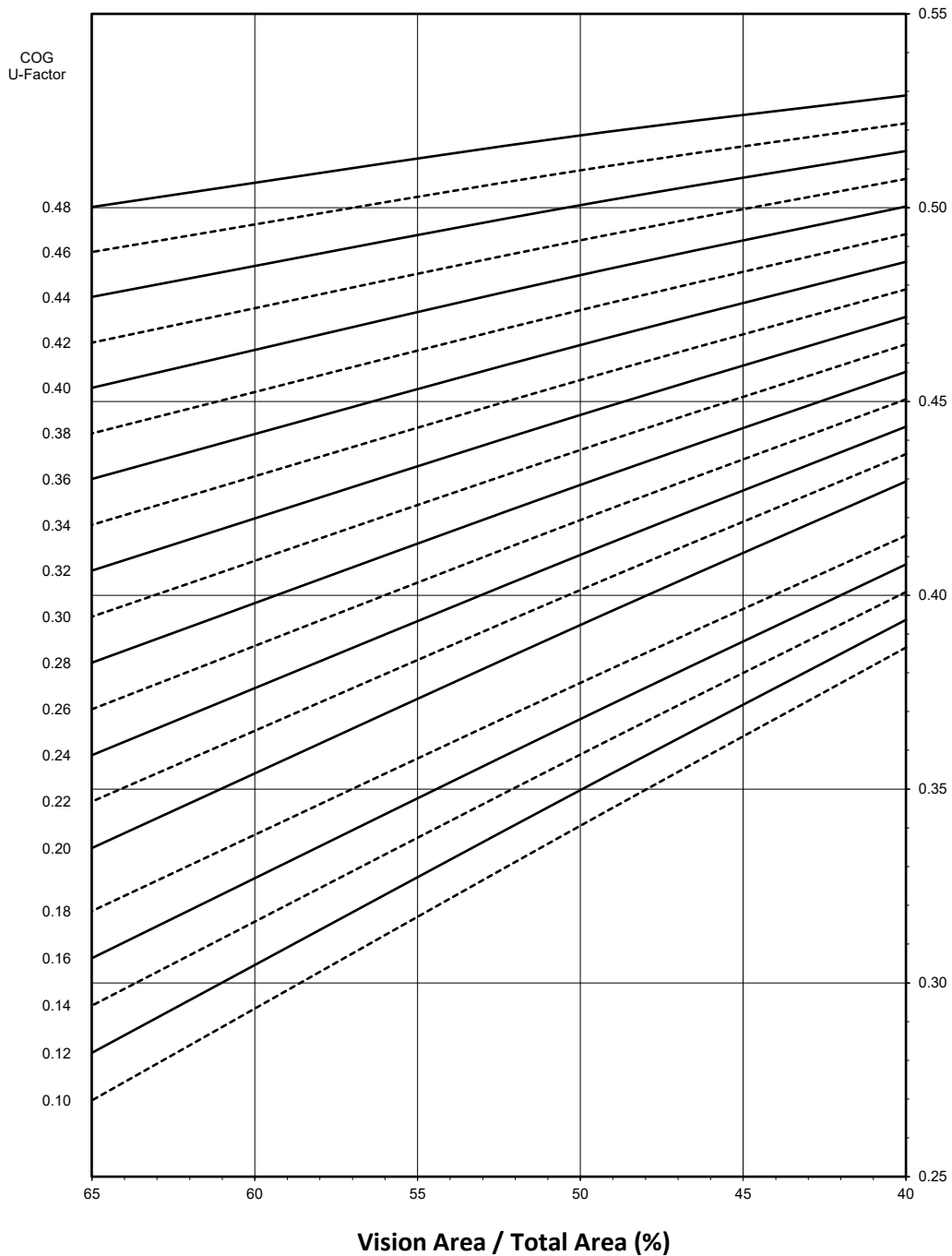

TEST REPORT FOR GAMCO CORPORATION

Report No.: Q0188.01-116-45 R0

Date: 10/18/23

SECTION 6

SIMULATION RESULTS

SHGC CALCULATIONS: System SHGC vs. Percentage of Vision Area

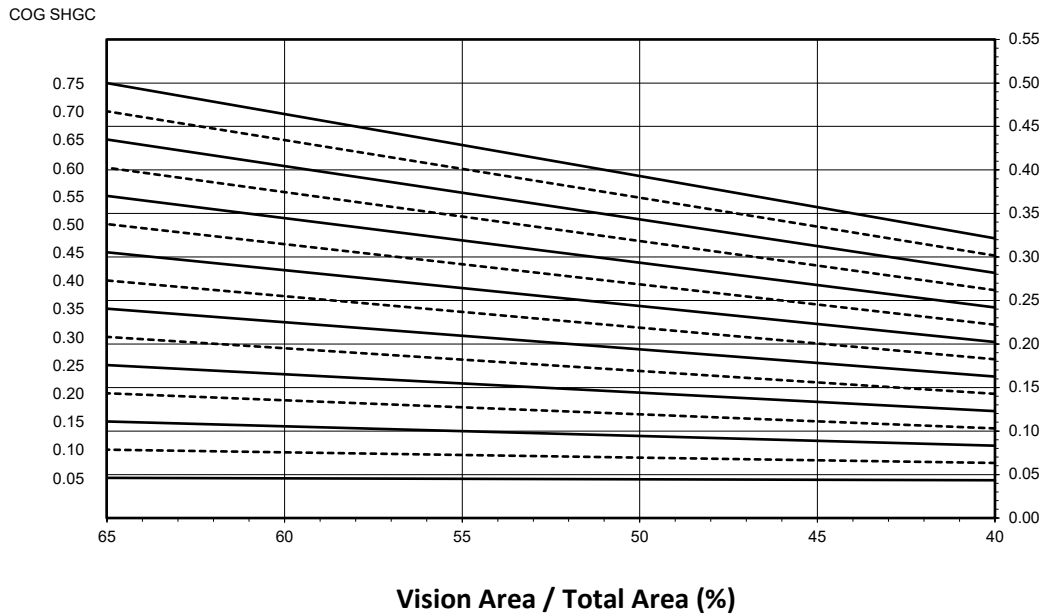

VT CALCULATIONS: System VT vs. Percentage of Vision Area

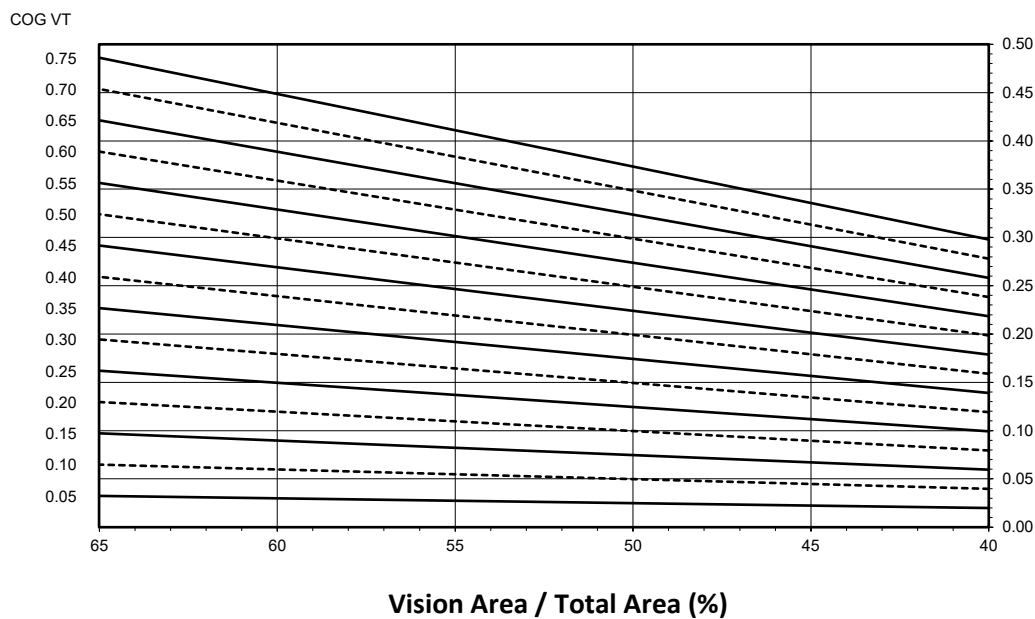

TEST REPORT FOR GAMCO CORPORATION

Report No.: Q0188.01-116-45 R0

Date: 10/18/23

SECTION 6

SIMULATION RESULTS

U-FACTOR CALCULATIONS (TD350 Door w/ FG451IS Frame Single Door - 1-3/8" IG (With Foam))		
Size Specific U-Factor Matrix*		
Glazing Option	Center-of-Glass U-Factor	Overall U-Factor
1	0.48	0.52
2	0.46	0.51
3	0.44	0.50
4	0.42	0.49
5	0.40	0.48
6	0.38	0.47
7	0.36	0.46
8	0.34	0.45
9	0.32	0.44
10	0.30	0.44
11	0.28	0.43
12	0.26	0.42
13	0.24	0.41
14	0.22	0.40
15	0.20	0.39
16	0.18	0.37
17	0.16	0.37
18	0.14	0.36
19	0.12	0.35
20	0.10	0.34

*The size specific U-Factor matrix is based on the Swinging Door - Single NFRC specimen size of 960mm x 2090mm (37.75 in x 82.375 in). This represents 50.7% Vision Area / Total Area.

TEST REPORT FOR GAMCO CORPORATION

Report No.: Q0188.01-116-45 R0

Date: 10/18/23

SECTION 6

SIMULATION RESULTS

SHGC/VT CALCULATIONS (TD350 Door w/ FG451IS Frame Single Door - 1-3/8" IG (With Foam))			
Size Specific SHGC Matrix*		Size Specific VT Matrix*	
Center-of-Glass SHGC	Overall SHGC	Center-of-Glass VT	Overall VT
0.75	0.40	0.75	0.38
0.70	0.37	0.70	0.35
0.65	0.35	0.65	0.33
0.60	0.32	0.60	0.30
0.55	0.30	0.55	0.28
0.50	0.27	0.50	0.25
0.45	0.25	0.45	0.23
0.40	0.22	0.40	0.20
0.35	0.20	0.35	0.18
0.30	0.17	0.30	0.15
0.25	0.15	0.25	0.13
0.20	0.12	0.20	0.10
0.15	0.10	0.15	0.08
0.10	0.07	0.10	0.05
0.05	0.04	0.05	0.03

*The size specific SHGC and VT matrices are based on the Swinging Door - Single NFRC specimen size of 960mm x 2090mm (37.75 in x 82.375 in). This represents 50.7% Vision Area / Total Area.

TEST REPORT FOR GAMCO CORPORATION

Report No.: Q0188.01-116-45 R0

Date: 10/18/23

SECTION 6

SIMULATION RESULTS

TOTAL PRODUCT CALCULATIONS (TD350 Door w/ FG451IS Frame Single Door - 1-3/8" IG (With Foam))									
Option Number	COG U-Factor	COG Temperature	Cross Section	Frame Height	Frame U-Factor	Edge U-Factor	Total Product U-Factor		
							40.00% Vision Area	ANSI/NFRC 100-2023	65.00% Vision Area
1	0.48	43.7°F	Head	6.6681	0.6343	0.5609	0.5289	0.5178	0.5002
			L. Jamb	6.6674	0.5620	0.5493			
			R. Jamb	6.6674	0.5620	0.5493			
			Sill	#####	0.4556	0.5416			
2	0.46	44.8°F	Head	6.6681	0.6338	0.5475	0.5218	0.5087	0.4886
			L. Jamb	6.6674	0.5612	0.5358			
			R. Jamb	6.6674	0.5612	0.5358			
			Sill	#####	0.4551	0.5279			
3	0.44	45.8°F	Head	6.6681	0.6332	0.5343	0.5146	0.4995	0.4770
			L. Jamb	6.6674	0.5605	0.5224			
			R. Jamb	6.6674	0.5605	0.5224			
			Sill	#####	0.4545	0.5144			
4	0.42	46.8°F	Head	6.6681	0.6327	0.5211	0.5074	0.4903	0.4652
			L. Jamb	6.6674	0.5597	0.5091			
			R. Jamb	6.6674	0.5597	0.5091			
			Sill	#####	0.4540	0.5010			
5	0.40	47.9°F	Head	6.6681	0.6322	0.5080	0.5003	0.4812	0.4535
			L. Jamb	6.6674	0.5590	0.4958			
			R. Jamb	6.6674	0.5590	0.4958			
			Sill	#####	0.4535	0.4877			
6	0.38	48.9°F	Head	6.6681	0.6317	0.4950	0.4932	0.4721	0.4418
			L. Jamb	6.6674	0.5583	0.4827			
			R. Jamb	6.6674	0.5583	0.4827			
			Sill	#####	0.4531	0.4745			
7	0.36	50.0°F	Head	6.6681	0.6311	0.4821	0.4860	0.4629	0.4300
			L. Jamb	6.6674	0.5576	0.4697			
			R. Jamb	6.6674	0.5576	0.4697			
			Sill	#####	0.4526	0.4614			
8	0.34	51.0°F	Head	6.6681	0.6307	0.4692	0.4789	0.4537	0.4182
			L. Jamb	6.6674	0.5569	0.4567			
			R. Jamb	6.6674	0.5569	0.4567			
			Sill	#####	0.4521	0.4484			

TEST REPORT FOR GAMCO CORPORATION

Report No.: Q0188.01-116-45 R0

Date: 10/18/23

SECTION 6

SIMULATION RESULTS

TOTAL PRODUCT CALCULATIONS (TD350 Door w/ FG451IS Frame Single Door - 1-3/8" IG (With Foam))									
Option Number	COG U-Factor	COG Temperature	Cross Section	Frame Height	Frame U-Factor	Edge U-Factor	Total Product U-Factor		
							40.00% Vision Area	ANSI/NFRC 100-2023	65.00% Vision Area
9	0.32	52.0°F	Head	6.6681	0.6302	0.4565	0.4718	0.4446	0.4064
			L. Jamb	6.6674	0.5563	0.4439			
			R. Jamb	6.6674	0.5563	0.4439			
			Sill	#####	0.4516	0.4354			
10	0.30	53.1°F	Head	6.6681	0.6297	0.4438	0.4647	0.4354	0.3945
			L. Jamb	6.6674	0.5556	0.4311			
			R. Jamb	6.6674	0.5556	0.4311			
			Sill	#####	0.4512	0.4225			
11	0.28	54.2°F	Head	6.6681	0.6292	0.4311	0.4577	0.4263	0.3826
			L. Jamb	6.6674	0.5550	0.4184			
			R. Jamb	6.6674	0.5550	0.4184			
			Sill	#####	0.4507	0.4097			
12	0.26	55.2°F	Head	6.6681	0.6288	0.4185	0.4506	0.4170	0.3706
			L. Jamb	6.6674	0.5544	0.4057			
			R. Jamb	6.6674	0.5544	0.4057			
			Sill	#####	0.4503	0.3970			
13	0.24	56.3°F	Head	6.6681	0.6283	0.4060	0.4435	0.4079	0.3588
			L. Jamb	6.6674	0.5538	0.3930			
			R. Jamb	6.6674	0.5538	0.3930			
			Sill	#####	0.4499	0.3843			
14	0.22	57.3°F	Head	6.6681	0.6279	0.3932	0.4364	0.3987	0.3468
			L. Jamb	6.6674	0.5532	0.3802			
			R. Jamb	6.6674	0.5532	0.3802			
			Sill	#####	0.4495	0.3714			
15	0.20	58.4°F	Head	6.6681	0.6275	0.3807	0.4294	0.3895	0.3348
			L. Jamb	6.6674	0.5526	0.3677			
			R. Jamb	6.6674	0.5526	0.3677			
			Sill	#####	0.4491	0.3588			
16	0.18	59.5°F	Head	6.6681	0.6208	0.3579	0.4154	0.3745	0.3185
			L. Jamb	6.6674	0.5422	0.3429			
			R. Jamb	6.6674	0.5422	0.3429			
			Sill	#####	0.4427	0.3336			

TEST REPORT FOR GAMCO CORPORATION

Report No.: Q0188.01-116-45 R0

Date: 10/18/23

SECTION 6

SIMULATION RESULTS

TOTAL PRODUCT CALCULATIONS (TD350 Door w/ FG451IS Frame Single Door - 1-3/8" IG (With Foam))									
Option Number	COG U-Factor	COG Temperature	Cross Section	Frame Height	Frame U-Factor	Edge U-Factor	Total Product U-Factor		
							40.00% Vision Area	ANSI/NFRC 100-2023	65.00% Vision Area
17	0.16	60.6°F	Head	6.6681	0.6206	0.3422	0.4080	0.3651	0.3064
			L. Jamb	6.6674	0.5419	0.3269			
			R. Jamb	6.6674	0.5419	0.3269			
			Sill	#####	0.4425	0.3178			
18	0.14	61.6°F	Head	6.6681	0.6201	0.3298	0.4009	0.3558	0.2942
			L. Jamb	6.6674	0.5412	0.3146			
			R. Jamb	6.6674	0.5412	0.3146			
			Sill	#####	0.4420	0.3054			
19	0.12	62.7°F	Head	6.6681	0.6198	0.3163	0.3937	0.3464	0.2820
			L. Jamb	6.6674	0.5407	0.3009			
			R. Jamb	6.6674	0.5407	0.3009			
			Sill	#####	0.4417	0.2918			
20	0.10	63.9°F	Head	6.6681	0.6194	0.3034	0.3865	0.3371	0.2697
			L. Jamb	6.6674	0.5402	0.2880			
			R. Jamb	6.6674	0.5402	0.2880			
			Sill	#####	0.4413	0.2788			



Total Quality. Assured.

130 Derry Court
York, PA, 17406

Telephone: 717-764-7700
Facsimile: 717-764-4129
www.intertek.com/building

TEST REPORT FOR GAMCO CORPORATION

Report No.: Q0188.01-116-45 R0

Date: 10/18/23

SECTION 7

DRAWINGS / BILL OF MATERIALS

The drawings which follow have been reviewed by Intertek B&C and are representative of the simulation result(s) reported herein. Any deviations are documented herein or on the drawings.

THERMAL UNITS



Report #: Q0188-116-45
 Date: 10/18/23
 Verified by: Allison M. Ford

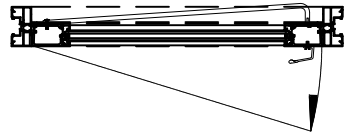
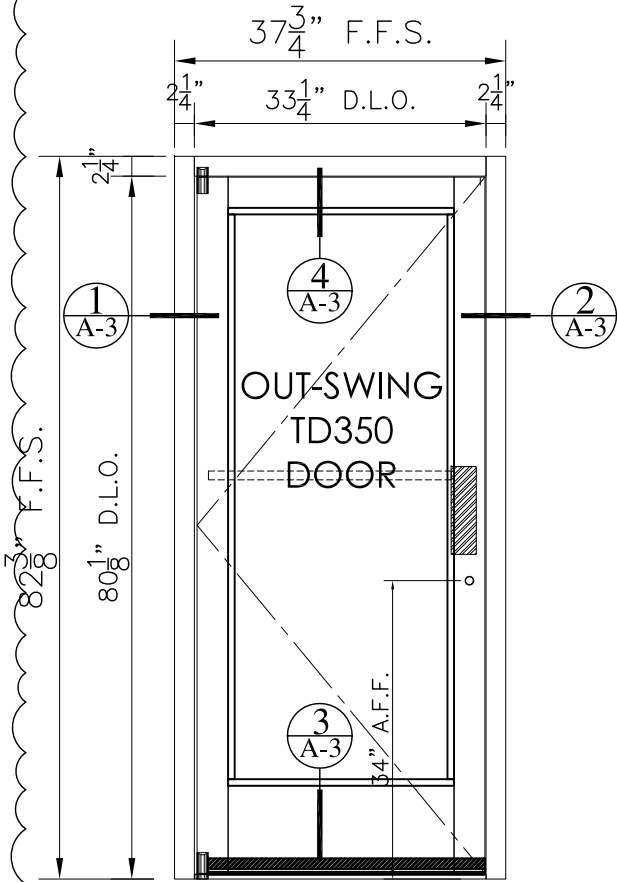

PLAN

QTY: 1 UNIT W/ 1-3/8" I.G.

1-3/8" GLASS SIZE: 25-9/16" X 65-3/8" - 1 PCS

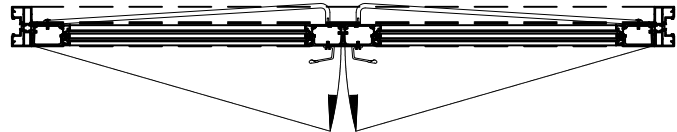
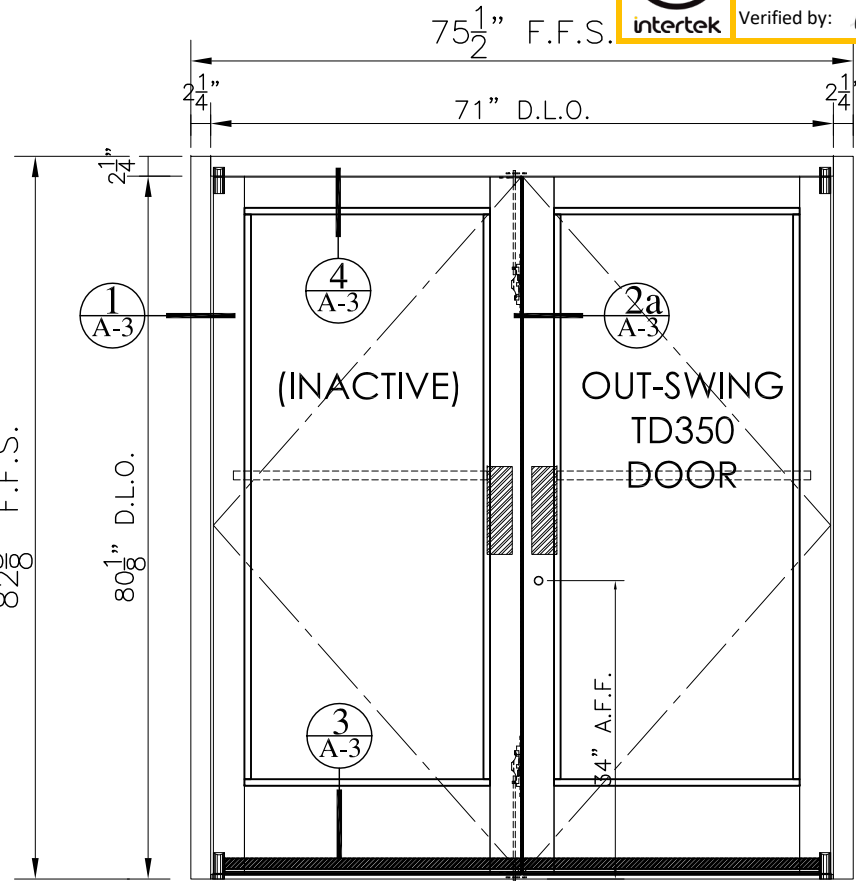

PLAN

QTY: 1 UNIT ~~W/~~ 1-3/8" I.G.

1-3/8" GLASS SIZE: 27-13/16" X 65-3/8" - 2 PCS

ALUMINUM STOREFRONT ELEVATIONS

* NOTE: ALL ELEVATIONS SHOWN TO BE VIEW FROM EXTERIOR.

SCALE: 3/8" = 1'-0"



Report #: Q0188-116-45

Date: 10/18/23

Verified by: *Allison M. Ford*

AAMA 507 - THERMAL TEST

MODEL TESTED: TD350 + FG451IS

GLAZING SET-UP FOR 1-3/8" O.A.

GLASS TYPE:

EXT: 1/4" THICKNESS

3/4" SPACER (ARGON)

INT: 3/8" THICKNESS

GLASS SIZE IS D.L.O. + 1.000

ALL POLYAMIDE INSULBAR'S PROPRIETARY THERMAL CONDUCTIVITY MATERIAL IS LISTED IN THE NFRC 101 DATABASE IN APPENDIX C, PROVIDED COMPANY "ENSINGER"

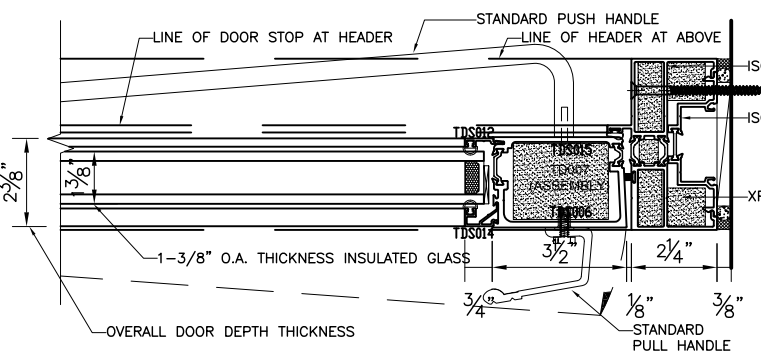
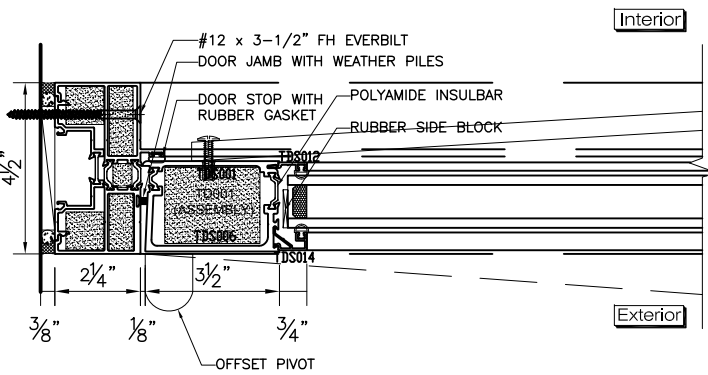
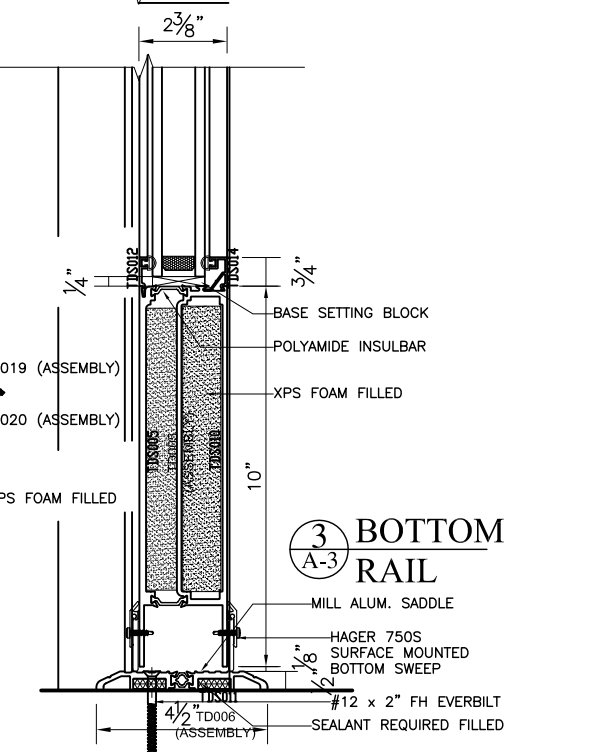
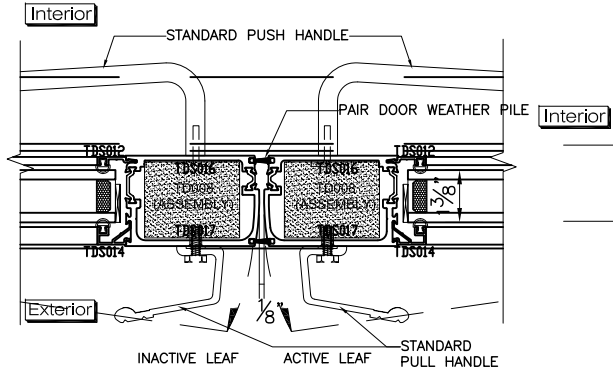
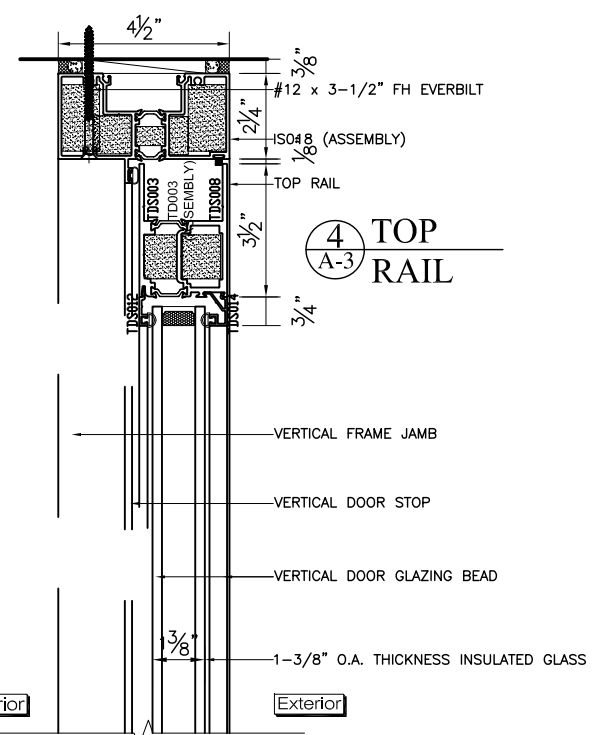

1 A-3 VERTICAL JAMB

2 A-3 VERTICAL JAMB

3 A-3 BOTTOM RAIL

HORIZONTAL SECTIONAL DETAILS

VERTICAL SECTIONAL DETAILS

SCALE : 3" = 1'-0"

SCALE : 3" = 1'-0"



TD350 DOOR - BOM LIST

THERMAL TESTING MOCK-UP

SINGLE DOOR - 1-3/8" I.G.



Report #: Q0188-116-45
Date: 10/18/23
Verified by: *Allison M Ford*

<u>LINE #</u>	<u>PART #</u>	<u>DESCRIPTION</u>	<u>MATERIAL</u>
1	TD001	HINGE STILE	6063-T5
2	TD003	3.5" TOP RAIL	6063-T5
3	TD005	10" BOTTOM RAIL	6063-T6
4	TDS012	1-3/8" GLAZING BEAD	6063-T5
5	TDS014	EXTERIOR GLAZING BEAD	6063-T5
6	TD007	LOCK STILE	6063-T5
7	TD015	DOOR SHEAR BLOCK	6063-T5
8	IS018	HEADER DOOR FRAME	6063-T5
9	IS019	JAMB DOOR FRAME	6063-T5
10	IS020	DEEP POCKET FILLER	6063-T5
11	TD006	4-1/2" SADDLE	6063-T5
12	S-13020	SADDLE CLIP	6063-T5
13	OFFSET(1)	3/4" OFFSET PIVOTS	6063-T6
14	1850	AR 1850 HOOK LOCK	
15	6032	GLAZING BEAD GASKET	EPDM
16	E273	DOOR STOP GASKET	EPDM



TD350 DOOR - BOM LIST

THERMAL TESTING MOCK-UP

SINGLE DOOR - 1-3/8" I.G.



Report #: Q0188-116-45

Date: 10/18/23

Verified by: *Allison M Ford*



<u>LINE #</u>	<u>PART #</u>	<u>DESCRIPTION</u>	<u>MATERIAL</u>
1	PILE(3)	WEATHER STRIPE	POLYPROPYLENE
2	SWEEP(1)	SURFACE DOOR SWEEP	6063-T5/EPDM
3	SETTING(3)	SETTING BLOCK	EPDM
4	FOAM	VARIES CUT SIZE FOAMS	XPS FOAM
5			
6			
7			
8			
9			
10			
11			
12			
13			
14			
15			
16			



TD350 DOOR - CUTTING LIST

THERMAL TESTING MOCK-UP

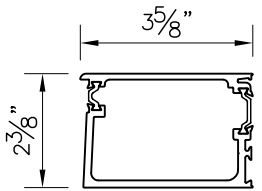
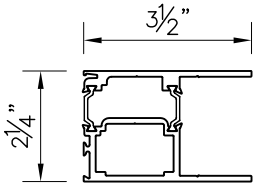
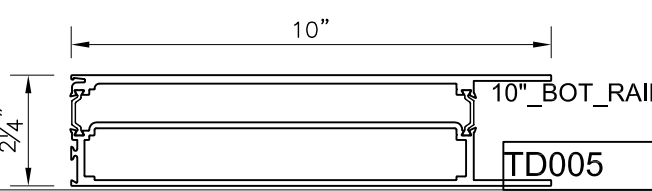
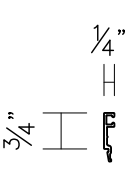
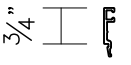
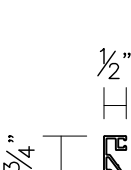
SINGLE DOOR - 1-3/8" I.G.

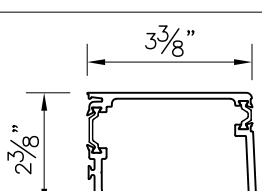
QTY.	PROFILE + PART #	COLOR	LENGTH (")
1	 HINGE_STILE TD001	AL	79.375"
1	 3.5\"_TOP_RAIL TD003	AL	26.001"
1	 10\"_BOT_RAIL TD005	AL	26.001"
2	 1-3/8\"_BEAD TDS012	AL	25.941"
2	 1-3/8\"_BEAD TDS012	AL	64.375"
2	 EXT_BEAD TDS014	AL	25.941"
2	 EXT_BEAD TDS014	AL	64.375"
1	 LOCK_STILE TD007	AL	79.375"

NOTE:





TD350 DOOR - CUTTING LIST

THERMAL TESTING MOCK-UP

SINGLE DOOR - 1-3/8" I.G. (FRAME)

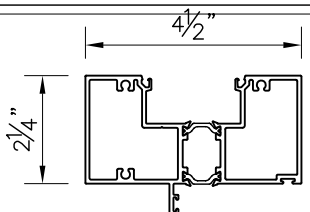
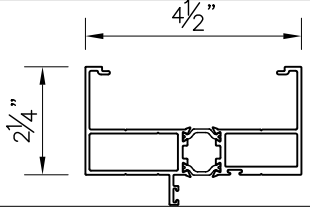
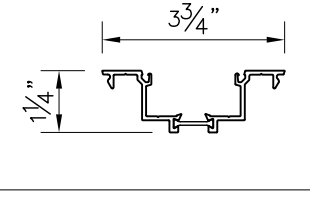
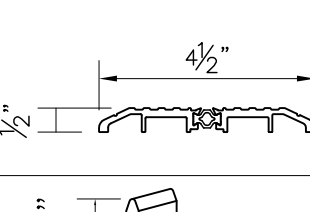
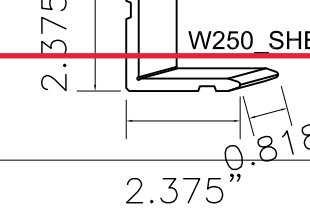
QTY.	PROFILE + PART #	COLOR	LENGTH (")
1	 HEADER_DOOR IS018	AL	33.250"
2	 JAMB_DOOR IS019	AL	82.375"
2	 DEEP_POCKET IS020	AL	82.375"
1	 4-1/2" _SADDLE TD006	MILL	33.250"
2	 W250 SHEAR_BLOCK SADDLE_CLIP S-13020	MILL	0.818"

NOTE:

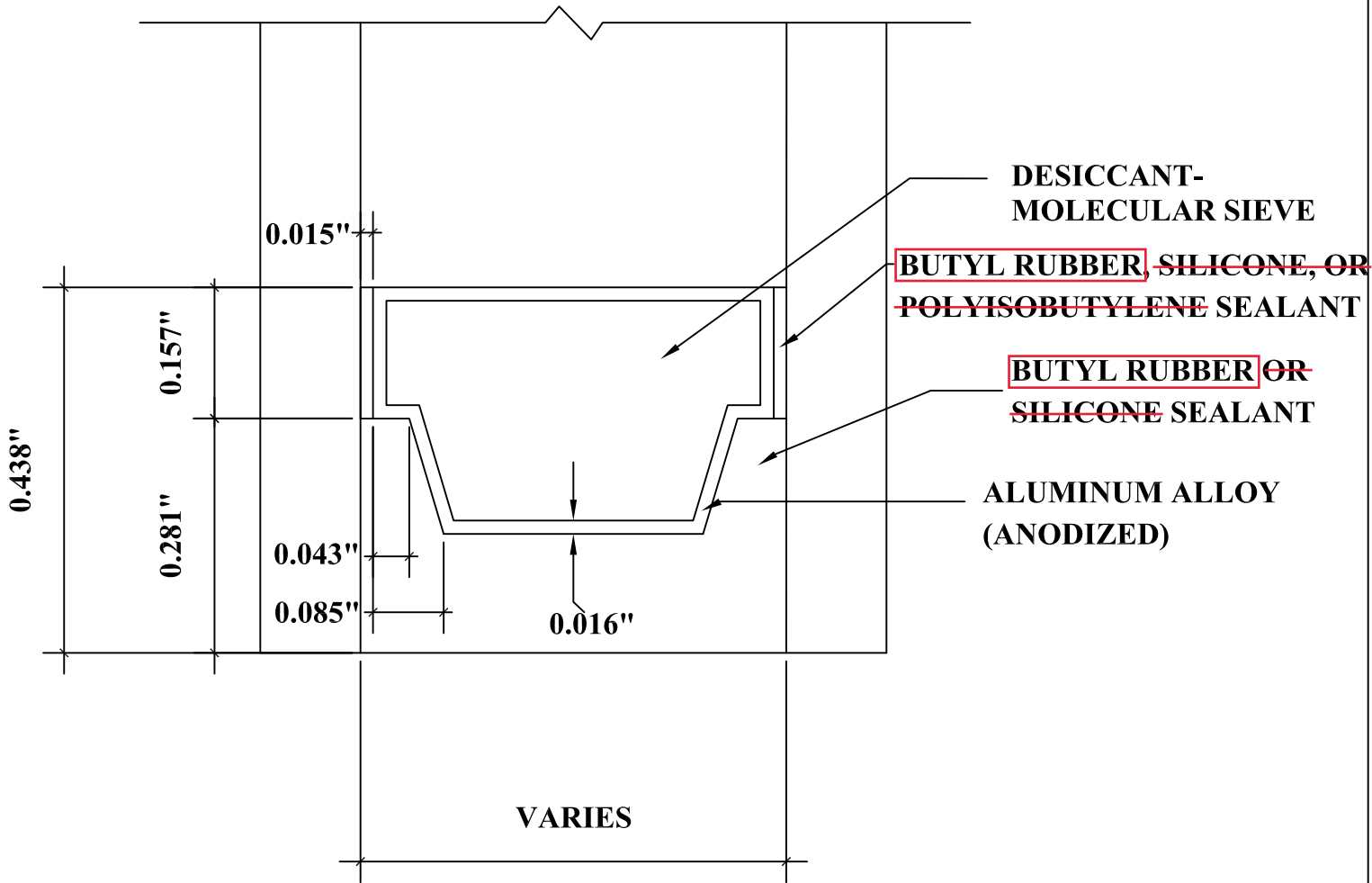

DETAIL FOR THERMAL MODELING OF
ALUMINUM SPACER (A1-D)

TEST REPORT FOR GAMCO CORPORATION

Report No.: Q0188.01-116-45 R0

Date: 10/18/23

SECTION 8

REVISION LOG

REVISION #	DATE	PAGES	REVISION
.01R0	10/18/23	N/A	Original Report Issued to Gamco Corporation.