



Est. 1986

FG450 FRAMES

1-3/4" x 4-1/2" Frame System (FG450)

Die #	Diagram	Description	Die #	Diagram	Description
S-15292		Single Pocket, Open Back with Screw Spline. Mates with S-15293, S-16275, S-7108, S-19576.	S-19576		Pocket Filler. Mates with S-15292, S-15293, S-15405, S-15721, S-15747, H-3084, H-3085, H-3087.
S-15293		Open Back Filler with Pocket. Mates with S-15292, S-15405, S-16275, S-19576, S-25168, S-25383, S-15691.	H-03084		Closed Back Sill. Mates with S-15295, S-16275, S-19576.
S-15295		Sill Cap. Mates with H-3084.	H-03085		Double Pocket Closed Back without Screw Spline. Mates with S-16275, S-19576.
S-15296		** Sill Shear Block.	H-03087		Single Pocket Closed Back. Mates with S-16275, S-19576.
S-15405		Single Pocket, Open Back without Screw Spline. Mates with S-15293, S-16275, S-7108, S-19576.	S-15691		135° Corner. Mates with S-15293, S-15286, S-7108.
S-15406		** Header Shear Block.	S-25169		Sill Cap. Mates with S-25169, S-25383.
S-15721		Half Corner with One Pocket. Mates with S-18380, S-15747, S-16275, S-19576.	S-25383		High Sill. Mates with S-25169, S-15293, S-7108.
S-15747		Half Corner with Two Pockets. Mates with S-18380, S-15721, S-16275, S-19576.	NW50370		Sub-sill.
S-16275		D-Series Door Stop. Mates with S-15292, S-15293, S-15405, S-15721, S-15747, H-3084, H-3085, H-3087.			
S-18380		Half Corner. Mates with S-15721, S-15747, S-15723, S-15724.			
S-07108		Open Back Flat Filler. Mates with S-15292, S-15405, S-25168, S-15691, S-15284, S-17758, S-25398, S-25383.			

*Available Finish: Clear Anodized, Dark Bronze Anodized, White Painted, Black Painted.

**All Stock Length 24'-0" OR 19'-6"; EXCEPT Shear Block Stock Length 6'-0".

Saddle Options

Die #	Diagram	Description	Die #	Diagram	Description
S-03688		4" Mill Saddle, 1/2" High.	S-10072		7" Mill Saddle, 1/2" High.
S-22315		5" Mill Handicap Saddle, 3/4" High.	S-19599		5" Panic Saddle with Stop, 7/16" High.

*Available Finish: Mill. 24'-0" Stock Length



Est. 1986

FG451 / FG451T FRAMES

2" x 4-1/2" Frame System (FG451)

Die #	Diagram	Description	Die #	Diagram	Description
S-15284		Single Pocket, Open Back with Screw Spline. Mates with S-15286, S-16276, S-7108, S-19577.	H-03088		Closed Back Sill. Mates with S-15301, S-16276, S-19577.
S-15286		Open Back Filler with Pocket. Mates with S-15284, S-17758, S-16276, S-19577, S-25398, S-25377, S-15691.	S-17758		Single Pocket, Open Back without Screw Spline. Mates with S-15286, S-16276, S-7108, S-19577.
S-15290		** Sill Shear Block.	S-19498		** Shear Block.
S-15301		Sill Cap. Mates with H-3088, S-23857.	S-19577		Pocket Filler. Mates with S-15284, S-15286, S-17758, S-15723, S-15724, H-3088, H-3089, H-3130.
S-15723		Half Corner with One Pocket. Mates with S-18380, S-15724, S-16276, S-19577.	S-22947		** Header Shear Block.
S-15724		Half Corner with Two Pockets. Mates with S-18380, S-15723, S-16276, S-19577.	S-23857		High Sill. Mates with S-15301, S-15286, S-7108.
S-16276		D-Series Door Stop. Mates with S-15284, S-15286, S-17758, S-15723, S-15724, H-3088, H-3089, H-3130.			
H-03089		Double Pocket Closed Back with Screw Spline. Mates with S-16276, S-19577.			
H-03130		Single Pocket Closed Back. Mates with S-16276, S-19577.			

*Available Finish: Clear Anodized, Dark Bronze Anodized, White Painted, Black Painted.

**All Stock Length 24'-0" OR 19'-6"; EXCEPT Shear Block Stock Length 6'-0".

2" x 4-1/2" Thermal Frame System (FG451T)

S-15300		Single Pocket, Open Back with Screw Spline. Thermally Broken. Mates with S-15916, S-17509, S16276.	H05406		Closed Back Sill. Thermally Broken. Mates with S-25397, S16276.
S-15916		Open Back Filler with Pocket. Thermally Broken. Mates with S-15300, S-25377, S16276.	S25377		High Sill. Thermally Broken. Mates with S-25397, S15916, S-17509.
S-17509		Open Back Flat Filler. Thermally Broken. Mates with S-15300, S-25377.	S-25397		Sill Cap. Mates with S-25377, H-5406.
S-15302		Sub-sill. Thermally Broken.			

*Available Finish: Clear Anodized, Dark Bronze Anodized, White Painted, Black Painted.

**All Stock Length 24'-0"; EXCEPT Shear Block Stock Length 6'-0".



Est. 1986

FG450 PICTORIAL VIEW

Screw Spline Assembly

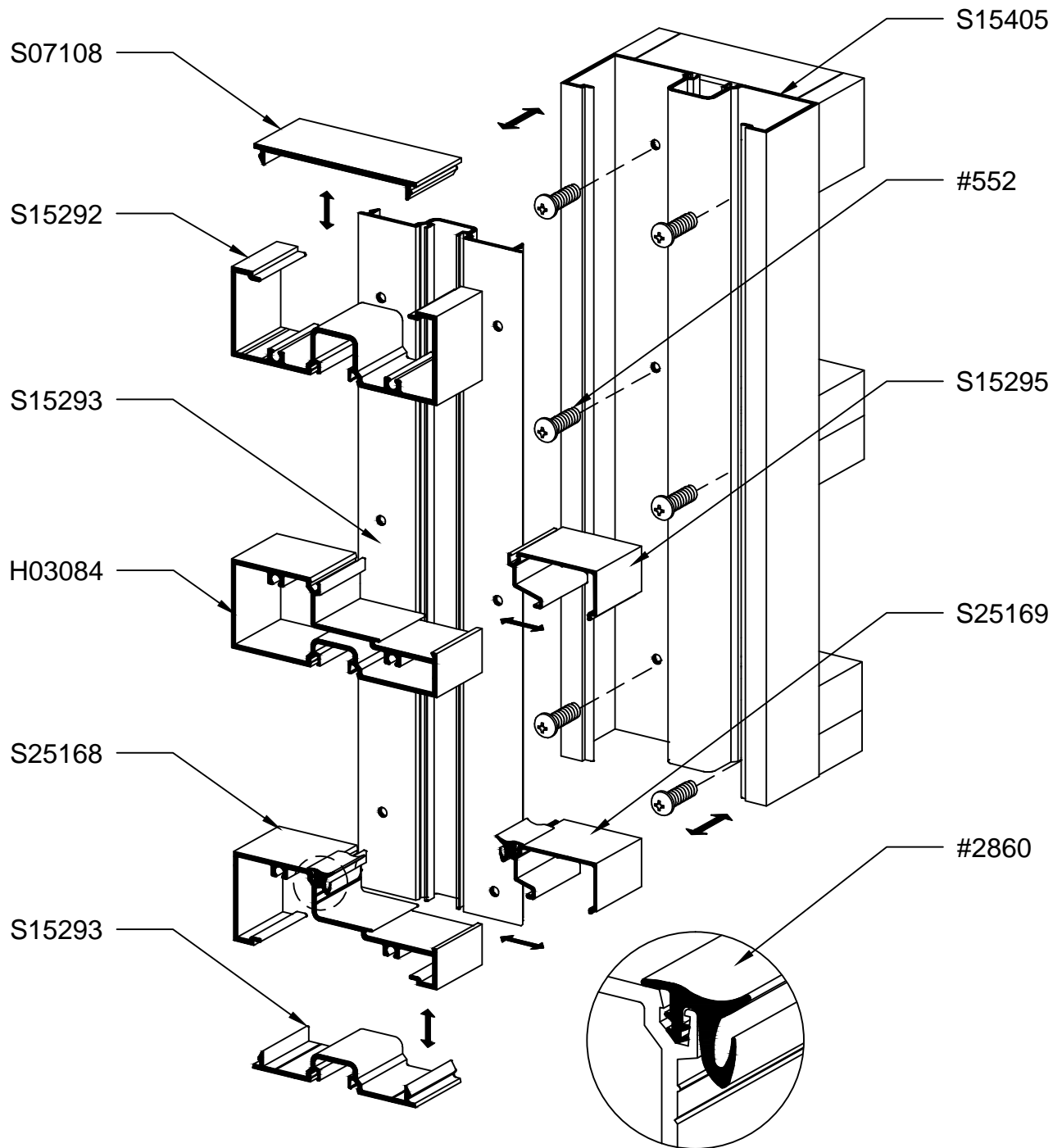



Est. 1986

FG450 PICTORIAL VIEW

Shear Block Assembly

