

TEST REPORT

AAMA 501
ASTM E283
ASTM E330
ASTM E331

REPORT No.: 2140.02-106-11

RENDERED TO: GAMCO CORPORATION
Flushing, New York

PRODUCT TYPE: Aluminum Fixed Storefront System

SERIES / MODEL: FG451

Test	Summary of Results
Design Pressure	±1440 Pa (±30.08 psf)
Air Infiltration @ 1.57 psf	0.3 L/s/m ² (0.06 cfm/ft ²)
Air Infiltration @ 6.24 psf	0.6 L/s/m ² (0.11 cfm/ft ²)
Air Exfiltration @ 1.57 psf	0.3 L/s/m ² (0.06 cfm/ft ²)
Air Exfiltration @ 6.24 psf	0.8 L/s/m ² (0.16 cfm/ft ²)
Water Penetration Resistance Test Pressure	580 Pa (12.11 psf)

Test Completion Date: 6/4/2020

Reference must be made to Report No. 2140.02-106-11, dated 7/16/2020 for complete test specimen description and detailed test results.

CLIENT INFORMATION: GAMCO CORPORATION
131-10 Maple Ave.
Flushing, New York 11355

TEST LABORATORY: Molimo, LLC
1410 Eden Road
York, Pennsylvania 17402
717-900-6034

PROJECT SUMMARY:

PRODUCT TYPE: Aluminum Fixed Storefront System

SERIES/MODEL: FG451

PROJECT SUMMARY:

Molimo, LLC was contracted to perform testing on the above referenced product. The results are tested values and were secured by using the designated test methods.

PROJECT DETAILS:

Test Dates: 6/4/2020

Test Record Retention End Date: 6/4/2024

Test Location: Molimo, LLC test facility in York, Pennsylvania.

Test Specimen Source: The test specimen was provided by the client. Representative samples of the test specimen will be retained by Molimo for a minimum of four years from the test completion date.

Drawing Reference: The test specimen drawings were supplied by the client. The test specimen construction was verified by Molimo and was found to be representative of the product tested. Test specimen drawings are located in Appendix C of this report.

WITNESSES:

The following representatives witnessed all or part of the testing.

Name	Company
Michael D. Stremmel, P.E.	Molimo, LLC
Joseph W. Enriquez	Molimo, LLC

TEST METHODS:

AAMA 501-15 – *Methods of Test for Exterior Walls*

ASTM E283-04(12) – *Standard Test Method for Determining Rate of Air Leakage Through Exterior Windows, Curtain Walls, and Doors Under Specified Pressure Differences Across the Specimen*

ASTM E330/E330M-14 – *Standard Test Method for Structural Performance of Exterior Windows, Doors, Skylights and Curtain Walls by Uniform Static Air Pressure Difference*

ASTM E331-00(16) – *Standard Test Method for Water Penetration of Exterior Windows, Skylights, Doors and Curtain Walls by Uniform Static Air Pressure Difference*

TEST SPECIMEN DESCRIPTION:

PRODUCT SIZES:

Overall Size: 2591 mm x 2746 mm (102" x 108-1/8")

Overall Area: 7.11 m² (76.58 ft²)

FRAME CONSTRUCTION:

Material: Extruded aluminum

Connection Details: Square-cut and butted, sealed with silicone, and secured with two #10 x 1" pan head screws per horizontal/vertical intersection

Other Details: All vertical members incorporated a 2-piece extruded aluminum member. The snap-on frame piece was secured to the main vertical member using #8 x 1/2" flat head screws, spaced a maximum of 16" on center.

The sill utilized an extruded sill pan with a 0.035" thick aluminum end dam. The end dam was secured to the sill pan with silicone.

REINFORCEMENT: No reinforcement was utilized.

TEST SPECIMEN DESCRIPTION: (Continued)

GLAZING DETAILS: *No conclusions of any kind regarding the adequacy or inadequacy of the glass in any glazed test specimen can be made.*

Description	Detail
Glass Type	1" IG
Glazing Construction (Exterior to Interior)	1/4" Thick tempered glass 1/2" Aluminum box spacer system 1/4" Thick tempered glass
Glazing Method	Channel glazed using interior and exterior glazing gaskets. The sill utilized a snap-in aluminum glazing bead on the exterior.
Glazing Bite	1/2"
Daylight Opening (2)	1207 mm x 2623 mm (47-1/2" x 103-1/4")

WEATHERSTRIPPING: No weatherstripping was utilized.

DRAINAGE:

Description	Quantity	Location
1-1/2" wide by 1/8" high weep slot	2	Each end of the sill between the sill pan and the storefront frame

HARDWARE: No hardware was utilized.

INSTALLATION: The specimen was installed into a 2x6 Pressure-Treated wood buck. The rough opening allowed for a 1/2" shim space. The exterior perimeter of the specimen was sealed with sealant.

Location	Anchor Description	Anchor Spacing
Head, Sill and Jamb	1/4" x 2-1/4" wood screw, through the glazing pocket into the wood buck	4" from each corner and spaced 14-1/2" on center

Note: *All installation screws had a maximum of 3/4" to 1" of penetration into the wood buck.*

TEST RESULTS: The temperature during testing was 25.3°C (77.6° F).

PRE-LOAD TESTING: (per ASTM E 330)

Test	Results	Allowable
+720 Pa (+15.04 psf) -720 Pa (-15.04 psf)	No Damage	No Damage

Note 1: All loads were held for 10 seconds.

AIR LEAKAGE TESTING: (per ASTM E 283)

Test	Results	Allowable
Infiltration @ 75 Pa (1.57 psf)	0.2 L/s/m ² (0.03 cfm/ft ²)	1.5 L/s/m ² (0.30 cfm/ft ²)
Infiltration @ 300 Pa (6.24 psf)	0.4 L/s/m ² (0.07 cfm/ft ²)	1.5 L/s/m ² (0.30 cfm/ft ²)
Exfiltration @ 75 Pa (1.57 psf)	0.1 L/s/m ² (0.02 cfm/ft ²)	1.5 L/s/m ² (0.30 cfm/ft ²)
Exfiltration @ 300 Pa (6.24 psf)	0.4 L/s/m ² (0.07 cfm/ft ²)	1.5 L/s/m ² (0.30 cfm/ft ²)

Note 2: Allowable Air Leakage is based on AAMA/WDMA/CSA 101/I.S.2/A440-17 for a CW-rated fixed window.

WATER PENETRATION TESTING: (per ASTM E 331)

Test	Results	Allowable
580 Pa (12.11 psf)	Pass	No Leakage

UNIFORM LOAD TESTING: (per ASTM E 330)

Design Pressure Test	Results	Allowable
Deflection measured at the vertical mullion		
+1440 Pa (+30.08 psf)	15.5 mm (0.61")	15.7 mm (0.62")
-1440 Pa (-30.08 psf)	14.7 mm (0.58")	15.7 mm (0.62")

Note 3: All loads were held for 10 seconds.

Note 4: Allowable Deflection is based on L/175 of the measured span.

Note 5: Tape and film were not used to seal against air leakage.

TEST RESULTS: (Continued)

REPEAT AIR LEAKAGE TESTING: (per ASTM E 283)

Test	Results	Allowable
Infiltration @ 75 Pa (1.57 psf)	0.3 L/s/m ² (0.06 cfm/ft ²)	1.5 L/s/m ² (0.30 cfm/ft ²)
Infiltration @ 300 Pa (6.24 psf)	0.6 L/s/m ² (0.11 cfm/ft ²)	1.5 L/s/m ² (0.30 cfm/ft ²)
Exfiltration @ 75 Pa (1.57 psf)	0.3 L/s/m ² (0.06 cfm/ft ²)	1.5 L/s/m ² (0.30 cfm/ft ²)
Exfiltration @ 300 Pa (6.24 psf)	0.8 L/s/m ² (0.16 cfm/ft ²)	1.5 L/s/m ² (0.30 cfm/ft ²)

Note 6: Allowable Air Leakage is based on AAMA/WDMA/CSA 101/I.S.2/A440-17 for a CW-rated fixed window.

REPEAT WATER PENETRATION TESTING: (per ASTM E 331)

Test	Results	Allowable
580 Pa (12.11 psf)	Pass	No Leakage

UNIFORM LOAD TESTING: (per ASTM E 330)

Structural Test	Results	Allowable
Permanent Set measured at the vertical mullion +2160 Pa (+45.11 psf)	3.0 mm (0.12")	5.6 mm (0.22")
-2160 Pa (-45.11 psf)	0.3 mm (0.01")	5.6 mm (0.22")

Note 7: All loads were held for 10 seconds.

Note 8: Allowable Permanent Set is based on 0.2% of the measured span.

Note 9: Tape and film were not used to seal against air leakage.

General Note: All testing was performed in accordance with reference test methods.

A copy of this report, detailed drawings, datasheets, representative samples of test specimens, or other pertinent project documentation will be retained by Molimo, LLC for the entire test record retention period. At the end of this retention period, the service life of this report will expire.

Results obtained are tested values and were secured by using the designated test methods. This test report does not constitute certification of this product nor an opinion or endorsement by this laboratory. It is the exclusive property of the client so named herein and relates only to the specimen(s) tested. This report may not be reproduced, except in full, without the written permission of Molimo, LLC.

For MOLIMO, LLC:

Joseph W. Enriquez
Project Manager

Michael D. Stremmel, P.E.
Senior Project Engineer

MDS:dro

Attachments (pages): This report is complete only when all attachments listed are included.

Appendix-A: Alteration Addendum (1)

Appendix-B: Air Seal Location (1)

Appendix-C: Drawings (1)

Appendix A

Alteration Addendum

No alterations were performed.

Appendix B

Air Seal Location

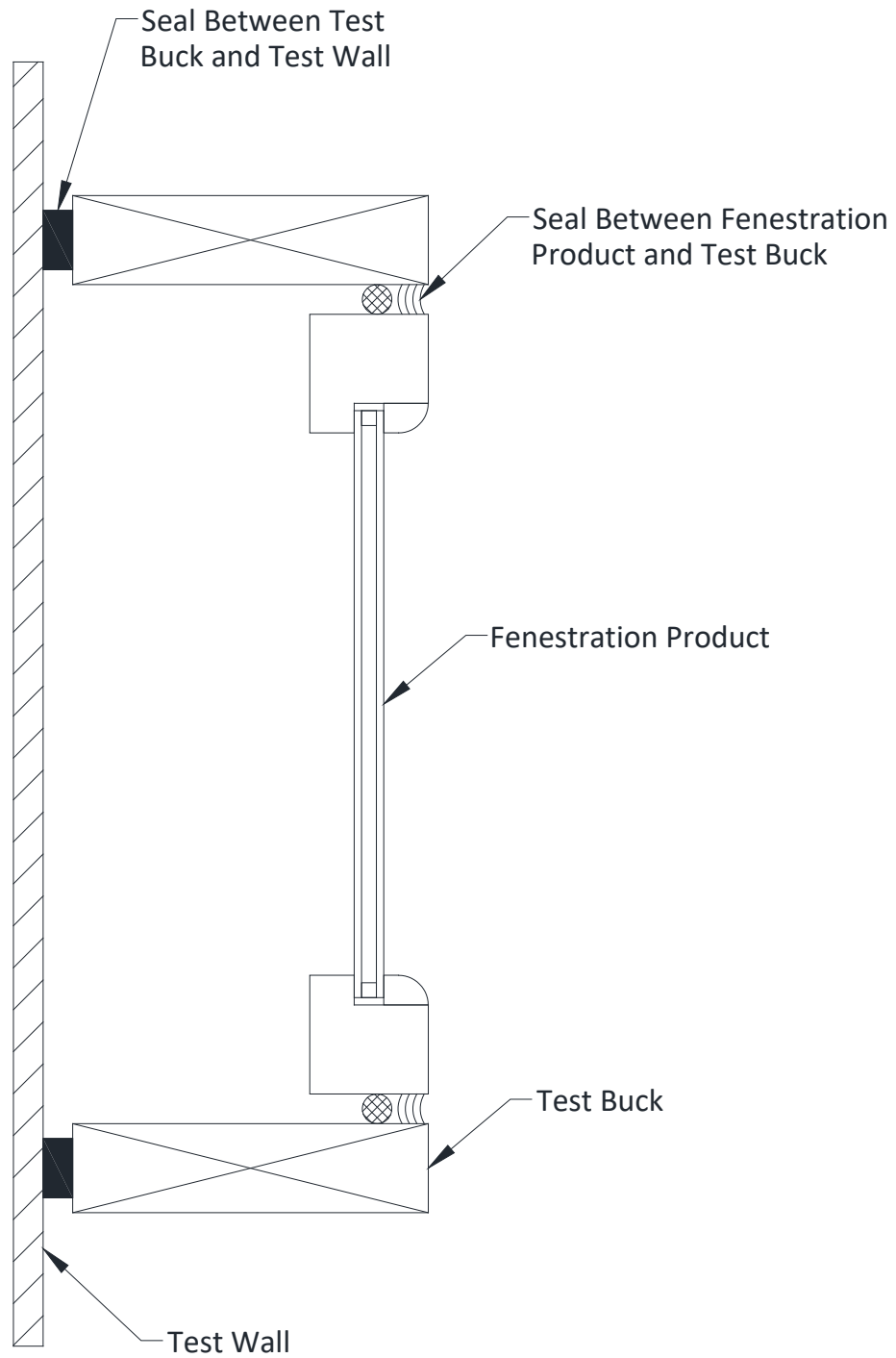

Appendix C

Drawings

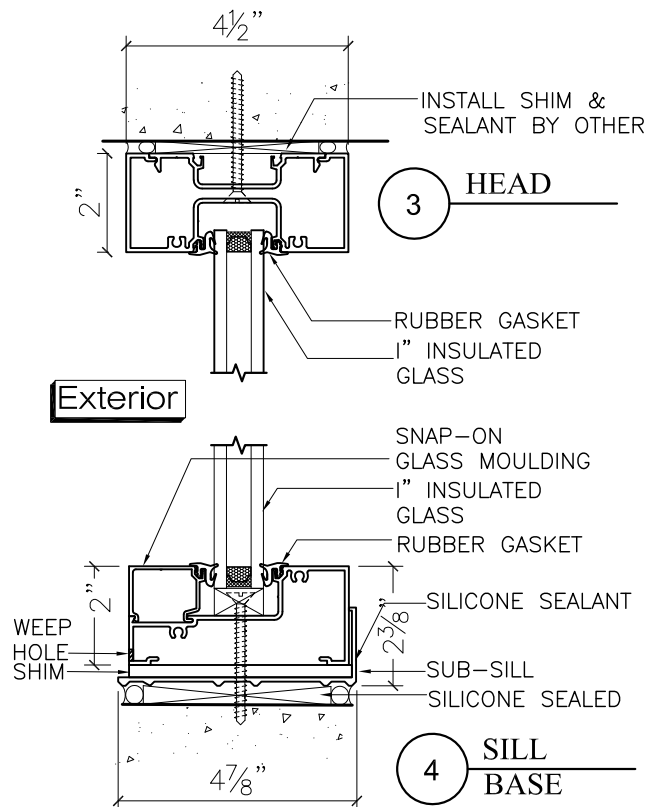
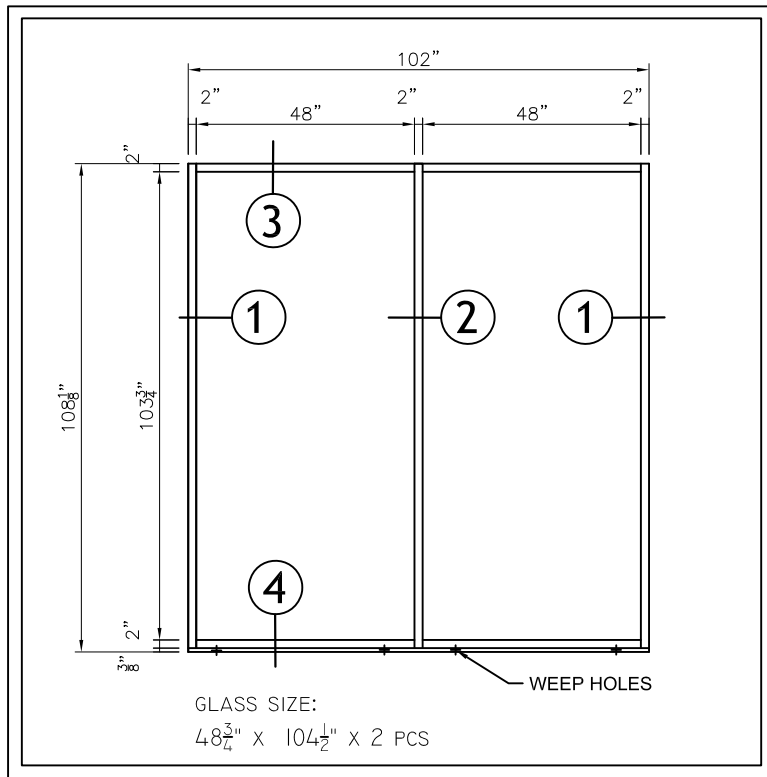

FG451 STOREFRONT

1" I.G. (1/4" CLR. TM. 1/2" AIR 1/4" CLR. TM.)

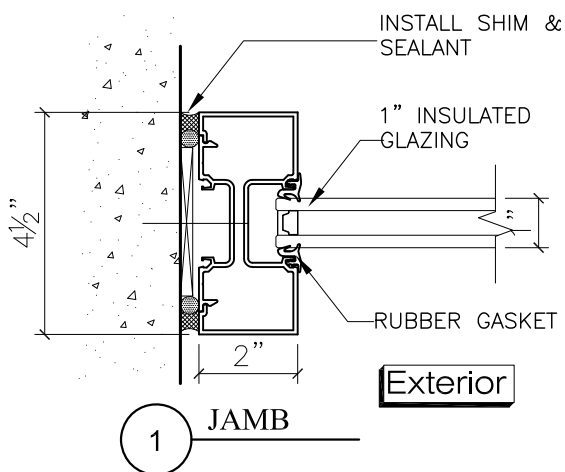
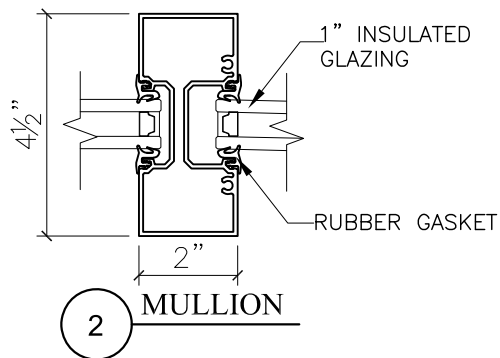

B	Drawn by: Q.ZHANG	Customer	Revisions			 GAMCO CORPORATION MANUFACTURERS OF FENESTRATION PRODUCTS 131-10 MAPLE AVE. FLUSHING, N.Y. 11355 TEL: (718)359-8833 FAX: (718)359-8661 info@gamcocorp.com www.gamcocorp.com
	Checked by: C.CHAN		No.	Date	Description	
	Date: 08/29/2018					
	Scale: 1/4" : 1"					
	Project : FG451 STOREFRONT					