

## TEST REPORT

AAMA 501  
ASTM E283  
ASTM E330  
ASTM E331

REPORT No.: 2140.01-106-11

RENDERED TO: GAMCO CORPORATION  
Flushing, New York

PRODUCT TYPE: Aluminum Fixed Storefront System

SERIES / MODEL: FG450

Test	Summary of Results
Design Pressure	±960 Pa (±20.05 psf)
Air Infiltration @ 1.57 psf	0.5 L/s/m <sup>2</sup> (0.09 cfm/ft <sup>2</sup> )
Air Infiltration @ 6.24 psf	1.0 L/s/m <sup>2</sup> (0.19 cfm/ft <sup>2</sup> )
Air Exfiltration @ 1.57 psf	0.5 L/s/m <sup>2</sup> (0.10 cfm/ft <sup>2</sup> )
Air Exfiltration @ 6.24 psf	0.9 L/s/m <sup>2</sup> (0.18 cfm/ft <sup>2</sup> )
Water Penetration Resistance Test Pressure	400 Pa (8.36 psf)

**Test Completion Date:** 6/18/2020

Reference must be made to Report No. 2140.01-106-11, dated 7/16/2020 for complete test specimen description and detailed test results.

**CLIENT INFORMATION:** GAMCO CORPORATION  
131-10 Maple Avenue  
Flushing, New York 11355

**TEST LABORATORY:** Molimo, LLC  
1410 Eden Road  
York, Pennsylvania 17402  
717-900-6034

**PROJECT SUMMARY:**

**PRODUCT TYPE:** Aluminum Fixed Storefront System

**SERIES/MODEL:** FG450

**PROJECT SUMMARY:**

Molimo, LLC was contracted to perform testing on the above referenced product. The results are tested values and were secured by using the designated test methods.

**PROJECT DETAILS:**

**Test Dates:** 6/8/2020 – 6/18/2020

**Test Record Retention End Date:** 6/18/2024

**Test Location:** Molimo, LLC test facility in York, Pennsylvania.

**Test Specimen Source:** The test specimen was provided by the client. Representative samples of the test specimen will be retained by Molimo for a minimum of four years from the test completion date.

**Drawing Reference:** The test specimen drawings were supplied by the client. The test specimen construction was verified by Molimo and was found to be representative of the product tested. Test specimen drawings are located in Appendix C of this report.

**WITNESSES:**

The following representatives witnessed all or part of the testing.

Name	Company
Michael D. Stremmel, P.E.	Molimo, LLC
Joseph W. Enriquez	Molimo, LLC

**TEST METHODS:**

AAMA 501-15 – *Methods of Test for Exterior Walls*

ASTM E283-04(12) – *Standard Test Method for Determining Rate of Air Leakage Through Exterior Windows, Curtain Walls, and Doors Under Specified Pressure Differences Across the Specimen*

ASTM E330/E330M-14 – *Standard Test Method for Structural Performance of Exterior Windows, Doors, Skylights and Curtain Walls by Uniform Static Air Pressure Difference*

ASTM E331-00(16) – *Standard Test Method for Water Penetration of Exterior Windows, Skylights, Doors and Curtain Walls by Uniform Static Air Pressure Difference*

**TEST SPECIMEN DESCRIPTION:**

**PRODUCT SIZES:**

Overall Size: 2572 mm x 2734 mm (101-1/4" x 107-5/8")

Overall Area: 7.03 m<sup>2</sup> (75.67 ft<sup>2</sup>)

**FRAME CONSTRUCTION:**

Material: Extruded aluminum

Connection Details: Square-cut and butted, sealed with silicone, and secured with two #10 x 1" pan head screws per horizontal/vertical intersection

Other Details: All vertical members incorporated a 2-piece extruded aluminum member. The snap-on frame piece was secured to the main vertical member using #8 x 1/2" flat head screws, spaced a maximum of 16" on center.

The sill utilized an extruded sill pan with a 0.035" thick aluminum end dam. The end dam was secured to the sill pan with silicone.

**REINFORCEMENT:** No reinforcement was utilized.

**TEST SPECIMEN DESCRIPTION:** (Continued)

**GLAZING DETAILS:** *No conclusions of any kind regarding the adequacy or inadequacy of the glass in any glazed test specimen can be made.*

Description	Detail
Glass Type	Monolithic
Glazing Construction (Exterior to Interior)	1/4" thick tempered glass
Glazing Method	Channel glazed using interior and exterior glazing gaskets. The sill utilized a snap-in aluminum glazing bead on the exterior.
Glazing Bite	1/2"
Daylight Opening (2)	1216 mm x 2635 mm (47-7/8" x 103-3/4")

**WEATHERSTRIPPING:** No weatherstripping was utilized.

**DRAINAGE:**

Description	Quantity	Location
1-1/2" wide by 1/8" high weep slot	2	Each end of the sill between the sill pan and the storefront frame

**HARDWARE:** No hardware was utilized.

**INSTALLATION:** The specimen was installed into a 2x6 Pressure-Treated wood buck. The rough opening allowed for a 1/2" shim space. The exterior perimeter of the specimen was sealed with sealant.

Location	Anchor Description	Anchor Spacing
Head, Sill and Jamb	1/4" x 2-1/4" wood screw, through the glazing pocket into the wood buck	4" from each corner and spaced 14-1/2" on center

**Note:** *All installation screws had a maximum of 3/4" to 1" of penetration into the wood buck.*

**TEST RESULTS:** The temperature during testing was 22.1°C (71.7° F).

**PRE-LOAD TESTING:** (per ASTM E 330)

Test	Results	Allowable
+480 Pa (+10.03 psf) -480 Pa (-10.03 psf)	No Damage	No Damage

*Note 1: All loads were held for 10 seconds.*

**AIR LEAKAGE TESTING:** (per ASTM E 283)

Test	Results	Allowable
Infiltration @ 75 Pa (1.57 psf)	0.5 L/s/m <sup>2</sup> (0.09 cfm/ft <sup>2</sup> )	1.5 L/s/m <sup>2</sup> (0.30 cfm/ft <sup>2</sup> )
Infiltration @ 300 Pa (6.24 psf)	1.0 L/s/m <sup>2</sup> (0.19 cfm/ft <sup>2</sup> )	1.5 L/s/m <sup>2</sup> (0.30 cfm/ft <sup>2</sup> )
Exfiltration @ 75 Pa (1.57 psf)	0.5 L/s/m <sup>2</sup> (0.10 cfm/ft <sup>2</sup> )	1.5 L/s/m <sup>2</sup> (0.30 cfm/ft <sup>2</sup> )
Exfiltration @ 300 Pa (6.24 psf)	0.9 L/s/m <sup>2</sup> (0.18 cfm/ft <sup>2</sup> )	1.5 L/s/m <sup>2</sup> (0.30 cfm/ft <sup>2</sup> )

*Note 2: Allowable Air Leakage is based on AAMA/WDMA/CSA 101/I.S.2/A440-17 for a CW-rated fixed window.*

**WATER PENETRATION TESTING:** (per ASTM E 331)

Test	Results	Allowable
400 Pa (8.36 psf)	Pass	No Leakage

**UNIFORM LOAD TESTING:** (per ASTM E 330)

Design Pressure Test	Results	Allowable
Deflection measured at the vertical mullion		
+960 Pa (+20.05 psf)	12.7 mm (0.50")	15.5 mm (0.61")
-960 Pa (-20.05 psf)	11.2 mm (0.44")	15.5 mm (0.61")

*Note 3: All loads were held for 10 seconds.*

*Note 4: Allowable Deflection is based on L/175 of the measured span.*

*Note 5: Tape and film were not used to seal against air leakage.*

**TEST RESULTS:** (Continued)

**REPEAT AIR LEAKAGE TESTING:** (per ASTM E 283)

Test	Results	Allowable
Infiltration @ 75 Pa (1.57 psf)	0.4 L/s/m <sup>2</sup> (0.08 cfm/ft <sup>2</sup> )	1.5 L/s/m <sup>2</sup> (0.30 cfm/ft <sup>2</sup> )
Infiltration @ 300 Pa (6.24 psf)	0.8 L/s/m <sup>2</sup> (0.15 cfm/ft <sup>2</sup> )	1.5 L/s/m <sup>2</sup> (0.30 cfm/ft <sup>2</sup> )
Exfiltration @ 75 Pa (1.57 psf)	0.4 L/s/m <sup>2</sup> (0.07 cfm/ft <sup>2</sup> )	1.5 L/s/m <sup>2</sup> (0.30 cfm/ft <sup>2</sup> )
Exfiltration @ 300 Pa (6.24 psf)	0.8 L/s/m <sup>2</sup> (0.16 cfm/ft <sup>2</sup> )	1.5 L/s/m <sup>2</sup> (0.30 cfm/ft <sup>2</sup> )

*Note 6: Allowable Air Leakage is based on AAMA/WDMA/CSA 101/I.S.2/A440-17 for a CW-rated fixed window.*

**REPEAT WATER PENETRATION TESTING:** (per ASTM E 331)

Test	Results	Allowable
400 Pa (8.36 psf)	Pass	No Leakage

**UNIFORM LOAD TESTING:** (per ASTM E 330)

Structural Test	Results	Allowable
Permanent Set measured at the vertical mullion +1440 Pa (+30.08 psf) -1440 Pa (-30.08 psf)	0.3 mm (0.01") 1.0 mm (0.04")	5.3 mm (0.21") 5.3 mm (0.21")

*Note 7: All loads were held for 10 seconds.*

*Note 8: Allowable Permanent Set is based on 0.2% of the measured span.*

*Note 9: Tape and film were not used to seal against air leakage.*

**General Note:** All testing was performed in accordance with reference test methods.

A copy of this report, detailed drawings, datasheets, representative samples of test specimens, or other pertinent project documentation will be retained by Molimo, LLC for the entire test record retention period. At the end of this retention period, the service life of this report will expire.

Results obtained are tested values and were secured by using the designated test methods. This test report does not constitute certification of this product nor an opinion or endorsement by this laboratory. It is the exclusive property of the client so named herein and relates only to the specimen(s) tested. This report may not be reproduced, except in full, without the written permission of Molimo, LLC.

For MOLIMO, LLC:

---

Joseph W. Enriquez  
Project Manager

---

Michael D. Stremmel, P.E.  
Senior Project Engineer

MDS:dro

Attachments (pages): This report is complete only when all attachments listed are included.

Appendix-A: Alteration Addendum (1)

Appendix-B: Air Seal Location (1)

Appendix-C: Drawings (1)

## **Appendix A**

### **Alteration Addendum**

#### Alteration #1

Date: 6/17/2020

Reason: Failed water penetration at 6.06 psf. Investigation revealed that end-dam was not sealed to the sub-sill.

Remedial Work: Sealed the end-dam to the sub-sill.



## Appendix B

### Air Seal Location

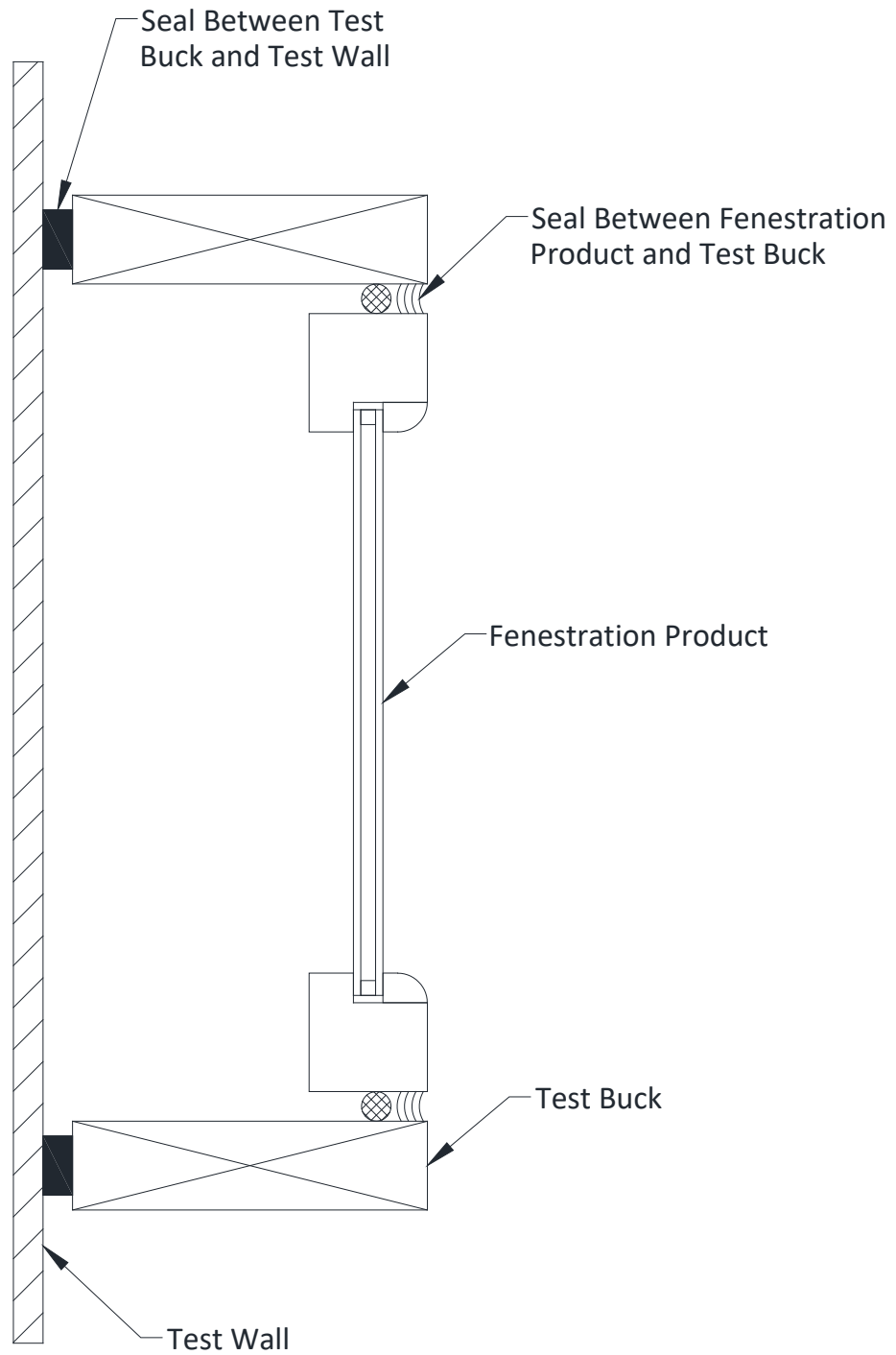

## **Appendix C**

### **Drawings**

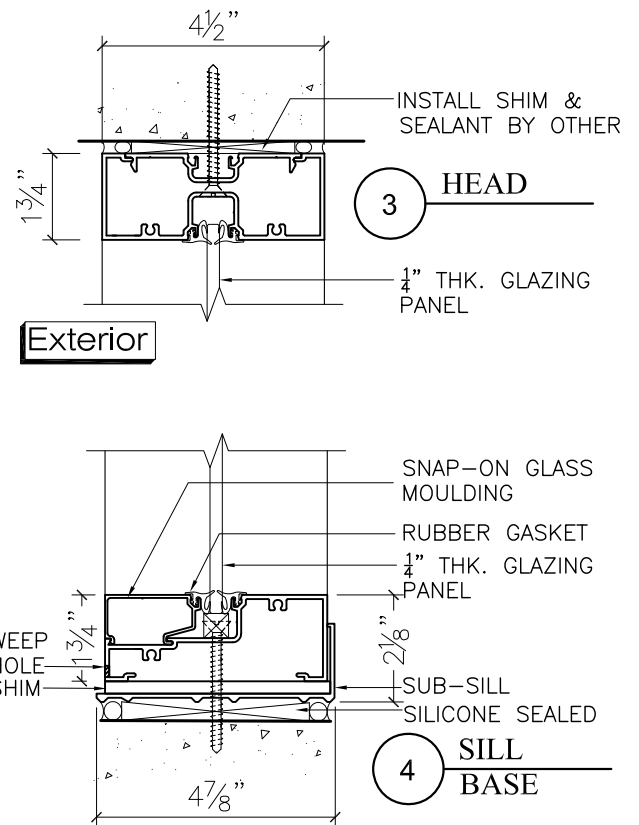
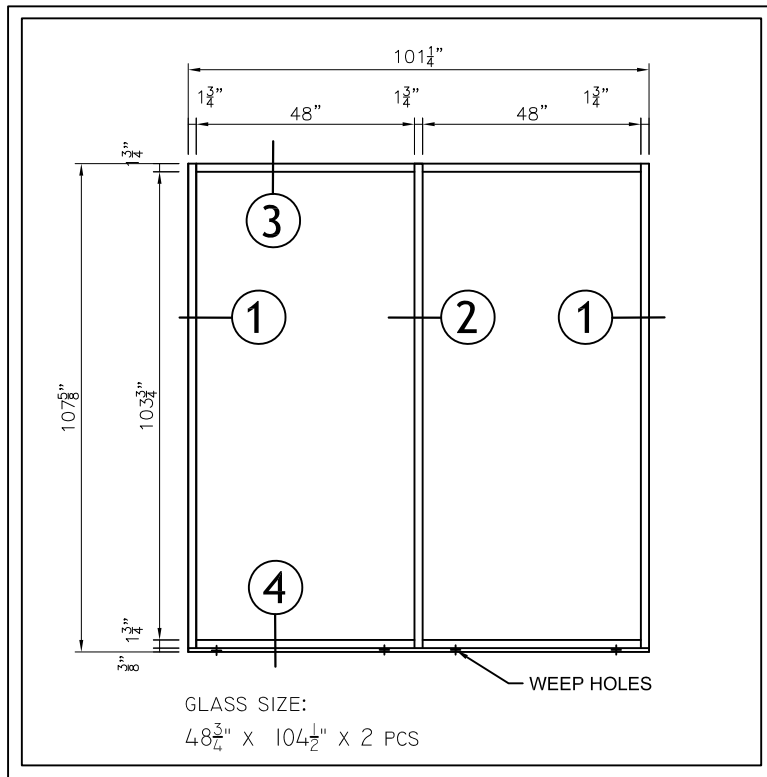

## FG450 STOREFRONT

1/4" CLR. TM. GLASS

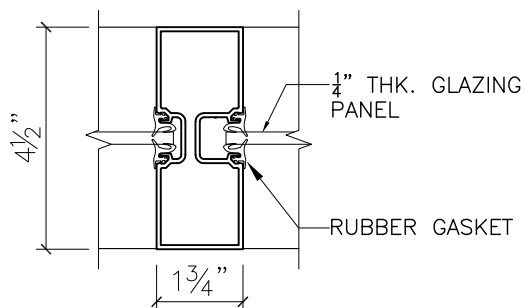

2 MULLION

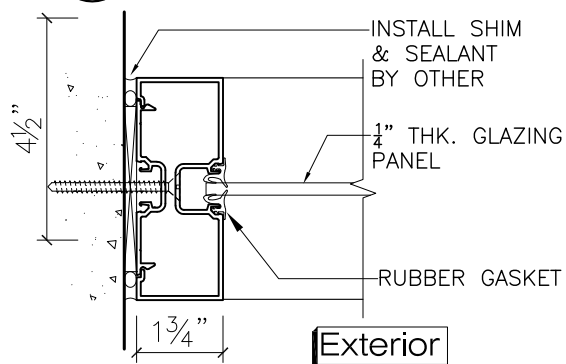

1 JAMB

<b>A</b>	Drawn by: <b>Q.ZHANG</b>	Customer	Revisions		
	Checked by: <b>C.CHAN</b>		No.	Date	Description
	Date: <b>08/29/2018</b>				
	Scale: <b>1/4" : 1"</b>				
	Project : <b>FG450 STOREFRONT</b>				



**GAMCO CORPORATION**  
 MANUFACTURERS OF FENESTRATION PRODUCTS  
 131-10 MAPLE AVE. FLUSHING, N.Y.11355  
 TEL: (718)359-8833 FAX: (718)359-8661  
 info@gamcocorp.com www.gamcocorp.com