

**BD-325 SERIES BALCONY DOOR**  
**SWING - OUT PAIR DOOR**

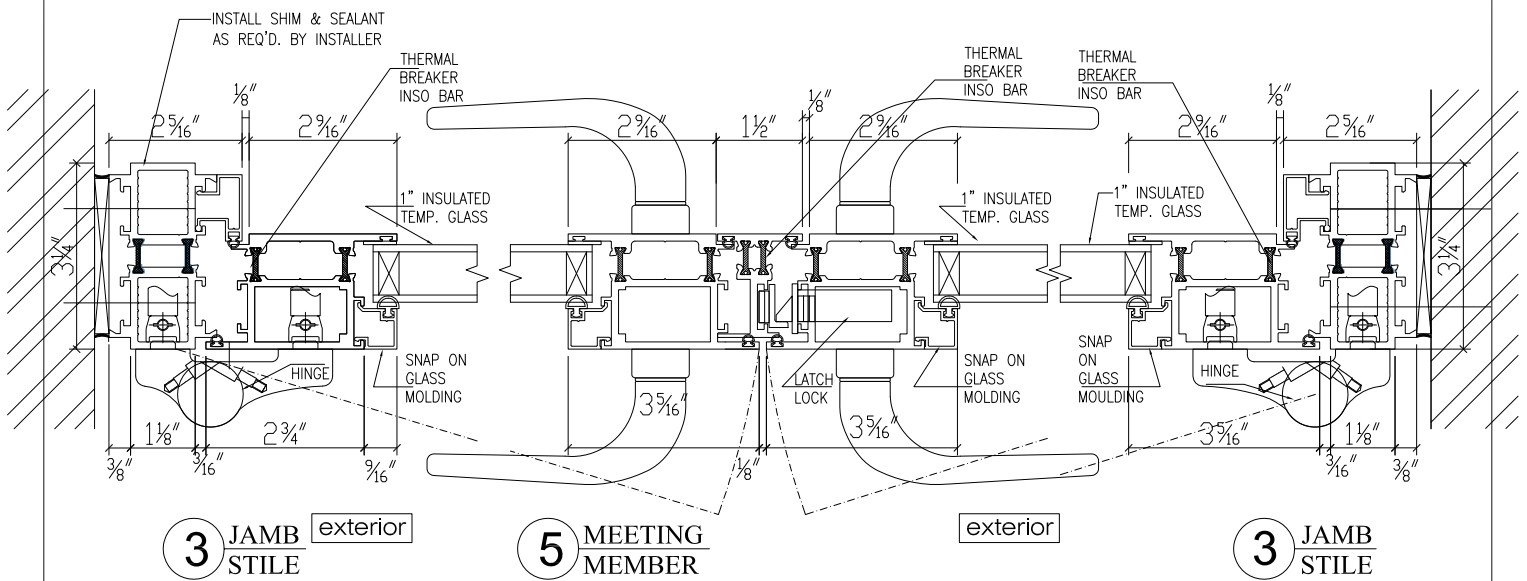
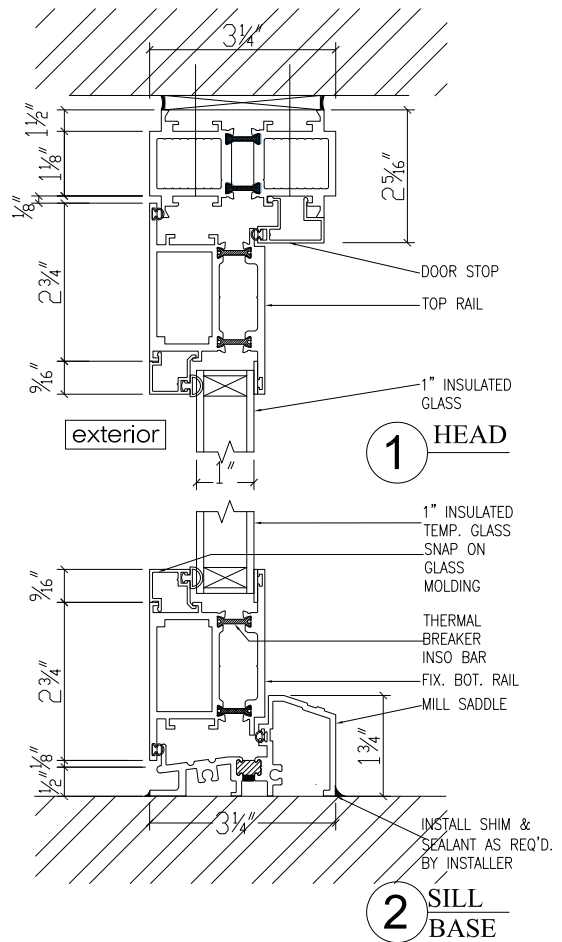

SHEET #

Drawn by:  
K. S. Lee  
 Checked by:  
C. CHAN  
 Date:  
 Scale:  
N.T.S.

Customer  
 Project :

Revisions

No.	Date	Description



**GAMCO CORPORATION**  
 MANUFACTURERS OF FENESTRATION PRODUCTS  
 131-10 MAPLE AVE. FLUSHING, N.Y. 11355  
 TEL: (718)359-8833 FAX: (718)359-8661  
 info@gamcocorp.com www.gamcocorp.com